



HB 6917 Bar Stool

Horst Brüning
1968



The designer

The German designer Horst Brüning created furniture that implemented the simple idea of minimalism, functionality, durability, timelessness and yet captures the spirit of the time.

Born in 1934, the German furniture designer Horst Brüning studied Architecture and Interior Design at the College of Graphic Arts in Hamburg until 1956. He also lived in Copenhagen and Stockholm, where he studied industrial design. In 1963 he set up an architecture and

design office in Stuttgart. During this period, Brüning came in contact with Kill International and the architect duo Fabricius & Kastholm, involving a successful exchange of ideas, which in the end led to international recognition and success.

Brüning and Fabricius & Kastholm's designs were originally manufactured by the same company, and have today been resumed by Lange Production to continue this original idea.

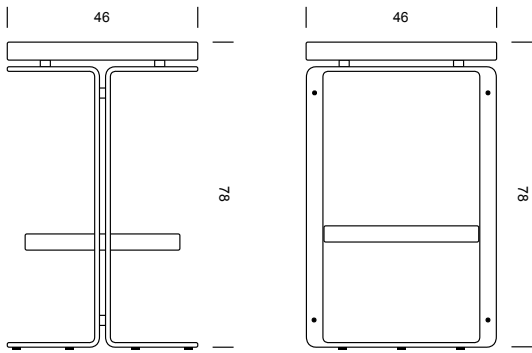

Materials Bar Stool in anilin leather. Frame in chrome-plated steel.

Leather colors Cognac
Dark Brown
Black

Measures H: 78 cm / 30,7 in
Ø: 46 cm / 18,1 in

COL ¼ hide approx.
Min. 70x105 cm / 27,6x41,3 in

Box weight 30 kg